



TECHNICAL FEATURES/ ĐẶC TÍNH KỸ THUẬT

Model/ Dòng sản phẩm	MBH	MRT1P & MRT3P	RCT	MR	PR	MSP	MCT	PCT
Casing/ Vỏ	PC	ABS	ABS	PVC tap	PVC tap	ABS	epoxy	epoxy
Primary current/ Dòng sơ cấp	50A- 3.000A	50A- 600A	50A- 2.000A	50A- 6.300A	100A- 6300/5A	100A- 6300A	5A- 20.000A	5A- 20.000A
Secondary current/ Dòng thứ cấp	5A	5A	5A	1A, 5A	1A, 5A	5A	1A, 5A	1A, 5A
Burden/ Công suất	Up to/ Lên đến 15VA	Up to/ Lên đến 3.75VA	Up to/ Lên đến 15VA	Up to/ Lên đến 40VA	Up to/ Lên đến 40VA	Up to/ Lên đến 25VA	Up to/ Lên đến 40VA	Up to/ Lên đến 40VA
Class/ Cấp chính xác	0.5	1.0	1.0	1.0 3.0	5P10, 10P10, 5P20	1.0	0.5,1.0, 3.0	5P10, 10P10, 5P20
Operating temperature/ Nhiệt độ làm việc	up to/ lên đến 110°C	-10÷60°C						
Rated Dynamic current/ Dòng điện động	Idyn: 2.5In							
Rated short-time thermal current/ Khả năng chịu dòng ngắn hạn	Ith: 60In during 1sec/ liên tục trong 1 giây							
Standing over current/ Khả năng chịu quá dòng	1.2In							
Voltage insulating/ Điện áp cách điện	660V							
Testing voltage/ Điện áp thử	3KV at 50/60Hz during 1 min/ liên tục trong 1 phút							
Standard Approval/ Theo tiêu chuẩn	IEC60044-1, EN60044-1, VDE0414-44-1, BS7626, IEC 61869							

*\*Other technical specifications can be made on request/ Kích thước tham khảo. Có thể sản xuất theo thông số khách hàng yêu cầu*

APPLICATION NOTE/ LƯU Ý

If the primary current is too small, to keep the same accuracy and burden, we can add primary winding to change the ratio of current transformer/

Nếu dòng điện sơ cấp là quá nhỏ, để đảm bảo độ chính xác và dung lượng, chúng ta có thể tăng số vòng dây sơ cấp để thay đổi tỉ số biến của biến dòng

Example/ Ví dụ:

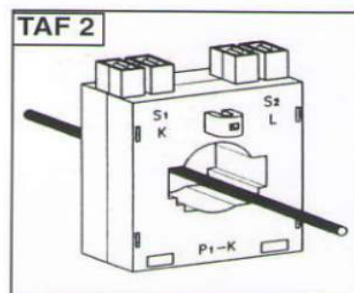



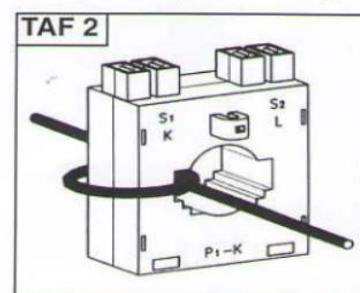



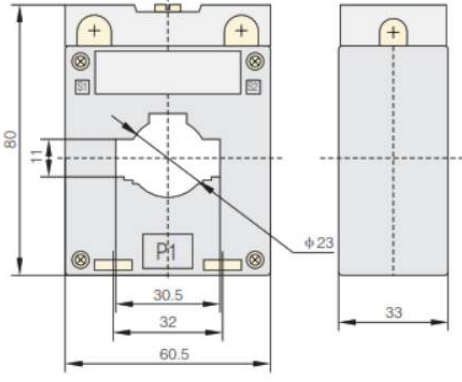

100/5A standard

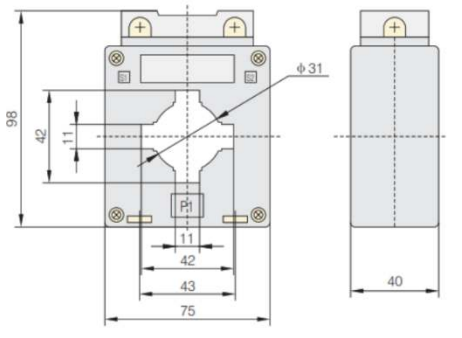

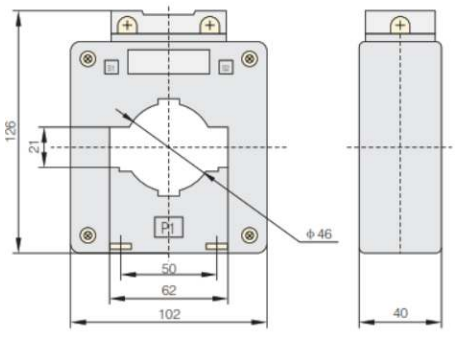

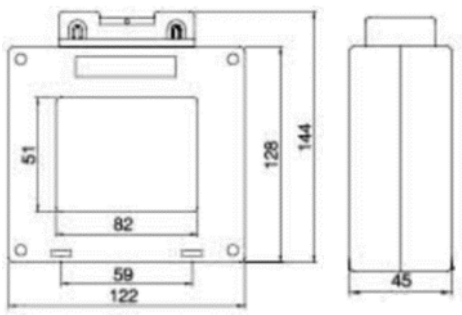

2 T Ratio = 50/5A

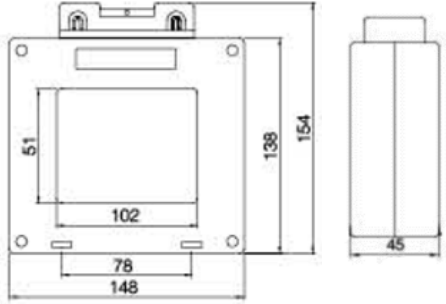
## ❖ MBH series

Model/ Mã	Ratio/ Tỉ số (A)	Class/ Cấp chính xác	Burden(VA)/ Dung lượng	Drawing & Dimension/ Bản vẽ và kích thước
 <b>MBH-30</b>	50/5 (2T)	0.5	2.5	
	75/5 (2T)	0.5	2.5	
	100/5	0.5	2.5	
	150/5	0.5	3.75	
	200/5	0.5	5	
 <b>MBH-40</b>	250/5	0.5	5	
	300/5	0.5	5	
	400/5	0.5	5	
	500/5	0.5	5	
	600/5	0.5	5	
 <b>MBH-60</b>	800/5	0.5	10	
	1000/5	0.5	15	
	1200/5	0.5	15	
 <b>MBH-80II (MBH-80B)</b>	800/5	0.5	15	
	1000/5	0.5	15	
	1200/5	0.5	15	
	1600/5	0.5	15	
	2000/5	0.5	15	

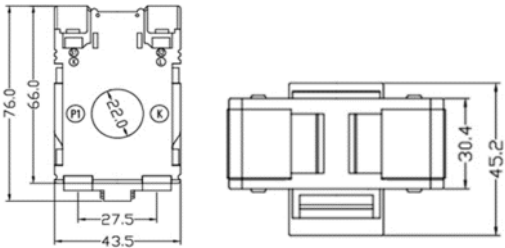
Model/ Mã	Ratio/ Tỉ số (A)	Class/ Cấp chính xác	Burden(VA)/ Dung lượng	Drawing & Dimension/ Bản vẽ và kích thước
 <b>MBH-100</b>	1600/5	0.5	15	
	2000/5	0.5	15	
	2500/5	0.5	15	
	3000/5	0.5	15	

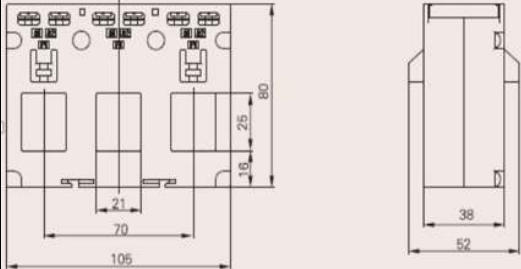
### ❖ MRT1P & MRT3P Series

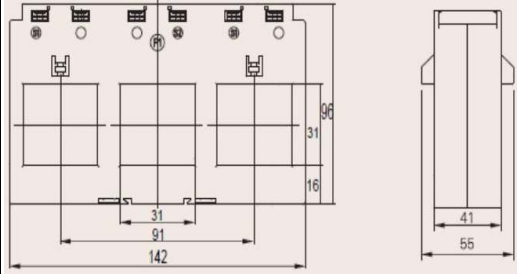
Model/ Mã	Ratio/ Tỉ số (A)	Class/ Cấp chính xác	Burden(VA)/ Dung lượng	Drawing & Dimension/ Bản vẽ và kích thước
 <b>MRT1P-20</b>	50/5	3.0	1.5	
	75/5	1.0	1.5	
	100/5	1.0	2.5	
	150/5	1.0	2.5	
	200/5	1.0	2.5	
 <b>MRT3P-105</b>	50/5	1.0	1.5	
	75/5	1.0	1.5	
	100/5	1.0	1.5	
	150/5	1.0	2.5	
	200/5	1.0	2.5	
 <b>MRT3P-140</b>	300/5	1.0	3.75	
	400/5	1.0	3.75	
	500/5	1.0	3.75	
	600/5	1.0	3.75	

## ❖ MR series

Photo/ Hình ảnh	Model/ Mã	Ratio/ Tỉ số (A)	Class/ Cấp chính xác	Burden/ Dung lượng (VA)	Dimension/ Kích thước (mm)			
					ID	OD	T	H
	MR-28	50/5	3.0	5	28	65	39	95
		75/5	3.0	5				
		50/5	3.0	10	28	65	60	95
		75/5	3.0	10				
		50/5	3.0	15	28	65	80	95
		75/5	3.0	15				
	MR-35	100/5	1.0	5	37	73	39	103
		150/5	1.0	5				
		200/5	1.0	5				
		250/5	1.0	5				
		300/5	1.0	5				
		100/5	1.0	10	37	73	55	103
		150/5	1.0	10				
		200/5	1.0	10				
		250/5	1.0	10				
		300/5	1.0	10				
		100/5	1.0	15	37	73	70	103
		150/5	1.0	15				
		200/5	1.0	15				
		250/5	1.0	15				
	300/5	1.0	15					
	MR-45	400/5	1.0	10	49	85	39	115
		500/5	1.0	10				
		600/5	1.0	10				
		400/5	1.0	15	49	85	55	115
		500/5	1.0	15				
		600/5	1.0	15				
	MR-65	400/5	1.0	10	65	110	39	145
		500/5	1.0	10				
		600/5	1.0	10				
		400/5	1.0	15	65	110	55	145
		500/5	1.0	15				
600/5		1.0	15					
MR-90	800/5	1.0	15	94	128	39	158	
	1000/5	1.0	15					
	1200/5	1.0	15					
	1250/5	1.0	15					
	800/5	1.0	20	94	128	55	158	
	1000/5	1.0	20					
	1200/5	1.0	20					
	1250/5	1.0	20					
MR-110	1600/5	1.0	15	110	141	39	171	
	2000/5	1.0	15					
	1600/5	1.0	15	110	141	55	171	
	2000/5	1.0	15					
MR-125	2500/5	1.0	15	132	175	39	205	
	3000/5	1.0	15					
	3200/5	1.0	15					
	4000/5	1.0	15					

Photo/ Hình ảnh	Model/ Mã	Ratio/ Tỉ số (A)	Class/ Cấp chính xác	Burden/ Dung lượng (VA)	Dimension/ Kích thước (mm)			
					ID	OD	T	H
	MR-125	2500/5	1.0	20	132	175	50	205
		3000/5	1.0	20				
		3200/5	1.0	20				
		4000/5	1.0	20				
	MR-200	5000/5	1.0	15	190	248	42	278
		6000/5	1.0	15				
		6300/5	1.0	15				
		5000/5	1.0	20	190	248	52	278
		6000/5	1.0	20				
		6300/5	1.0	20				

\*Dimension for reference. Other technical specifications can be made on request/ Kích thước tham khảo. Có thể sản xuất theo thông số khách hàng yêu cầu

Drawing/ bản vẽ

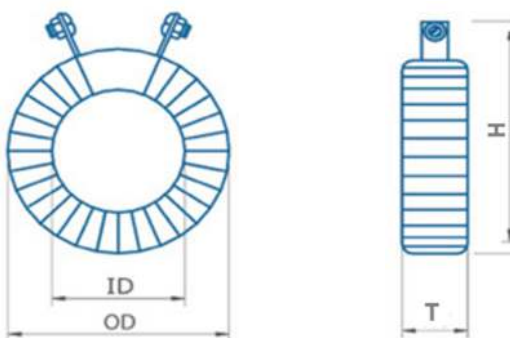

#### ❖ PR series

Photo/ Hình ảnh	Model/ Mã	Ratio/ Tỉ số (A)	Class/ Cấp chính xác	Burden (VA)/ Dung lượng	Dimension (mm)/ Kích thước			
					ID	OD	T	H
	PR-28	100/5	5P10	5	28	115	80	145
		150/5	5P10	5	28	95	80	125
		100/5	5P10	10	28	115	110	145
		150/5	5P10	10	28	95	110	125
		150/5	5P10	15	28	120	130	150
	PR-30	200/5	5P10	5	30	95	70	125
		250/5	5P10	5	30	90	70	120
		300/5	5P10	5	30	90	60	120
		200/5	5P10	10	30	110	70	140
		250/5	5P10	10	30	100	80	130
		300/5	5P10	10	30	100	70	130
		200/5	5P10	15	30	120	90	150
		250/5	5P10	15	30	110	90	140
		300/5	5P10	15	30	100	90	130
	PR-35	150/5	5P10	20	35	120	115	150
		200/5	5P10	20	35	110	115	140
	PR-40	250/5	5P10	20	40	115	85	145
		300/5	5P10	20	40	110	85	140

Photo/ Hình ảnh	Model/ Mã	Ratio/ Tỉ số (A)	Class/ Cấp chính xác	Burden (VA)/ Dung lượng	Dimension (mm)/ Kích thước			
					ID	OD	T	H
	PR-45	400/5	5P10	5	45	95	60	125
		400/5	5P10	10	45	100	70	130
		400/5	5P10	15	45	105	80	135
		400/5	5P10	20	45	110	85	140
	PR-55	500/5	5P10	5	55	100	60	130
		600/5	5P10	5	55	100	60	130
		500/5	5P10	10	55	105	70	135
		600/5	5P10	10	55	105	70	135
		500/5	5P10	15	55	115	70	145
		600/5	5P10	15	55	110	70	140
		500/5	5P10	20	55	125	80	155
		600/5	5P10	20	55	120	80	150
	PR-75	800/5	5P10	15	75	130	60	160
		1000/5	5P10	15	75	130	60	160
		1200/5	5P10	15	75	130	50	160
		1250/5	5P10	15	75	130	50	160
		800/5	5P10	20	75	130	75	160
		1000/5	5P10	20	75	130	75	160
		1200/5	5P10	20	75	130	65	160
		1250/5	5P10	20	75	130	65	160
	PR-90	1600/5	5P10	15	90	140	50	170
		1600/5	5P10	20	90	140	65	170
	PR-130	2000/5	5P10	15	130	185	40	215
		2500/5	5P10	15	130	185	40	215
		3000/5	5P10	15	130	185	40	215
		3200/5	5P10	15	130	185	40	215
		2000/5	5P10	20	130	185	50	215
		2500/5	5P10	20	130	185	50	215
		3000/5	5P10	20	130	185	50	215
		3200/5	5P10	20	130	185	50	215
	PR-160	4000/5	5P10	15	160	215	40	245
		5000/5	5P10	15	160	215	40	245
6000/5		5P10	15	160	215	40	245	
6300/5		5P10	15	160	215	40	245	
4000/5		5P10	20	160	215	40	245	
5000/5		5P10	20	160	215	40	245	
6000/5		5P10	20	160	215	40	245	
6300/5		5P10	20	160	215	40	245	

*\*Dimension for reference. Other technical specifications can be made on request/ Kích thước tham khảo. Có thể sản xuất theo thông số khách hàng yêu cầu*

**Drawing/ bản vẽ**

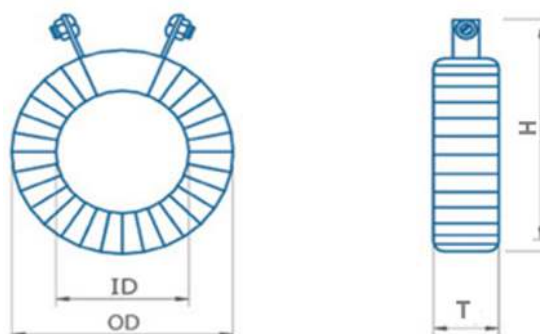



## ❖ RCT series

Photo/ Hình ảnh	Model/ Mã	Ratio/ Tỉ số (A)	Class/ Cấp chính xác	Burden/ Dung lượng (VA)	Dimension/ Kích thước (mm)			
					ID	OD	T	H
	RCT-35	50/5	1.0	5	34	77	52	102
		75/5	1.0	5				
		100/5	1.0	5				
		150/5	1.0	5				
		200/5	1.0	5				
		250/5	1.0	5				
		300/5	1.0	5				
	RCT-45	400/5	1.0	10	44	87	51	112
		500/5	1.0	10				
	RCT-65	500/5	1.0	10	65	110	54	135
		600/5	1.0	10				
	RCT-90	800/5	1.0	15	88	133	52	158
		1000/5	1.0	15				
		1200/5	1.0	15				
	RCT-110	1000/5	1.0	15	110	150	52	175
		1600/5	1.0	15				
		2000/5	1.0	15				

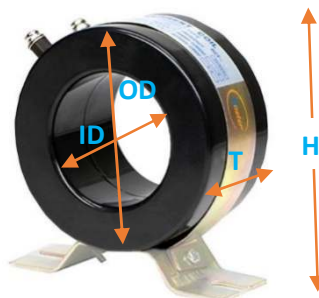
Drawing/ bản vẽ



**MEASURING CURRENT TRANSFORMER (MCT) – ROUND TYPE/  
BIẾN DÒNG ĐO LƯỜNG (MCT) - LOẠI TRÒN**

Photo/ Hình ảnh	Order code/ Mã đặt hàng	Ratio/ Tỉ số (A)	Class/ CCX	Burden/ Dung lượng (VA)	Dimension (mm)/ Kích thước			
					ID	OD	T	H
	MCT/20/1/5	20/5	1.0	5VA		110	105	165
	MCT/30/1/5	30/5	1.0	5VA		110	105	165
	MCT/40/1/5	40/5	1.0	5VA		110	105	165
	MCT/50/1/5	50/5	1.0	5VA		110	105	165
	MCT/60/1/5	60/5	1.0	5VA		110	105	165
	MCT/75/1/5	75/5	1.0	5VA		110	105	165
	MCT/20/1/10	20/5	1.0	10VA		110	115	175
	MCT/30/1/10	30/5	1.0	10VA		110	115	175
	MCT/40/1/10	40/5	1.0	10VA		110	115	175
	MCT/50/1/10	50/5	1.0	10VA		110	115	175
	MCT/60/1/10	60/5	1.0	10VA		110	115	175
	MCT/75/1/10	75/5	1.0	10VA		110	115	175
	MCT/20/1/15	20/5	1.0	15VA		110	125	185
	MCT/30/1/15	30/5	1.0	15VA		110	125	185
	MCT/40/1/15	40/5	1.0	15VA		110	125	185
	MCT/50/1/15	50/5	1.0	15VA		110	125	185
	MCT/60/1/15	60/5	1.0	15VA		110	125	185
MCT/75/1/15	75/5	1.0	15VA		110	125	185	
	MCT/50/3/5	50/5	3.0	5VA	25	100	80	120
	MCT/60/3/5	60/5	3.0	5VA	25	100	80	120
	MCT/75/3/5	75/5	3.0	5VA	25	100	70	120
	MCT/100/1/5	100/5	1.0	5VA	25	75	70	95
	MCT/150/1/5	150/5	1.0	5VA	25	70	50	95
	MCT/200/1/5	200/5	1.0	5VA	30	80	40	95
	MCT/250/1/5	250/5	1.0	5VA	30	75	40	95
	MCT/300/1/5	300/5	1.0	5VA	30	75	40	95
	MCT/400/1/5	400/5	1.0	5VA	45	85	40	100
	MCT/500/1/5	500/5	1.0	5VA	55	95	40	110
	MCT/600/1/5	600/5	1.0	5VA	55	95	40	110
	MCT/100/1/10	100/5	1.0	10VA	25	85	80	105
	MCT/150/1/10	150/5	1.0	10VA	25	80	60	105
	MCT/200/1/10	200/5	1.0	10VA	30	80	50	95
	MCT/250/1/10	250/5	1.0	10VA	30	75	50	95
	MCT/300/1/10	300/5	1.0	10VA	30	80	50	95
	MCT/400/1/10	400/5	1.0	10VA	45	90	40	105
	MCT/500/1/10	500/5	1.0	10VA	55	100	40	115
	MCT/600/1/10	600/5	1.0	10VA	55	100	40	115
	MCT/200/1/15	200/5	1.0	15VA	30	90	50	95
	MCT/250/1/15	250/5	1.0	15VA	30	85	50	95
	MCT/300/1/15	300/5	1.0	15VA	30	90	50	95
	MCT/400/1/15	400/5	1.0	15VA	45	100	40	105
	MCT/500/1/15	500/5	1.0	15VA	55	105	40	115
	MCT/600/1/15	600/5	1.0	15VA	55	105	40	115
	MCT/800/1/15	800/5	1.0	15VA	75	115	35	130
	MCT/1000/1/15	1000/5	1.0	15VA	75	115	35	130
	MCT/1200/1/15	1200/5	1.0	15VA	75	115	35	130
	MCT/1250/1/15	1250/5	1.0	15VA	75	115	35	130



Photo/ Hình ảnh	Order code/ Mã đặt hàng	Ratio/ Tỉ số (A)	Class/ CCX	Burden/ Dung lượng (VA)	Dimension (mm)/ Kích thước			
					ID	OD	T	H
	MCT/1600/1/15	1600/5	1.0	15VA	90	130	35	145
	MCT/2000/1/15	2000/5	1.0	15VA	130	170	35	185
	MCT/2500/1/15	2500/5	1.0	15VA	130	170	35	185
	MCT/3000/1/15	3000/5	1.0	15VA	130	170	35	185
	MCT/3200/1/15	3200/5	1.0	15VA	130	170	35	185
	MCT/4000/1/15	4000/5	1.0	15VA	160	210	35	225
	MCT/5000/1/15	5000/5	1.0	15VA	160	210	35	225
	MCT/6000/1/15	6000/5	1.0	15VA	160	210	35	225
MCT/6300/1/15	6300/5	1.0	15VA	160	210	35	225	

**MEASURING CURRENT TRANSFORMER (MCT) – SQUARE TYPE/  
BIẾN DÒNG ĐO LƯỜNG (MCT) – LOẠI HÌNH CHỮ NHẬT**

Photo/ Hình ảnh	Order code/ Mã đặt hàng	Ratio/ Tỉ số (A)	Class/ CCX	Burden/ Dung lượng (VA)	Dimension (mm)/ Kích thước			
					ID	OD	T	H
	MCT/1000/1/15/S	1000/5	1.0	15VA	50x105	100x155	35	130
	MCT/1200/1/15/S	1200/5	1.0	15VA	50x105	100x155	35	130
	MCT/1250/1/15/S	1250/5	1.0	15VA	50x105	100x155	35	130
	MCT/1600/1/15/S	1600/5	1.0	15VA	50 x 105	100 x 155	35	130
	MCT/2000/1/15/S	2000/5	1.0	15VA	50 x 105	100 x 155	35	130
	MCT/2500/1/15/S	2500/5	1.0	15VA	50 x 105	100 x 155	35	130
	MCT/3000/1/15/S	3000/5	1.0	15VA	70 x 140	110 x 180	35	140
	MCT/3200/1/15/S	3200/5	1.0	15VA	70 x 140	110 x 180	35	140
	MCT/4000/1/15/S	4000/5	1.0	15VA	100 x 170	160 x 220	35	180
	MCT/5000/1/15/S	5000/5	1.0	15VA	100 x 170	160 x 220	35	180
	MCT/6000/1/15/S	6000/5	1.0	15VA	100 x 170	160 x 220	35	180
	MCT/6300/1/15/S	6300/5	1.0	15VA	100 x 170	160 x 220	35	180

*\*Dimension for reference. Other technical specifications can be made on request/ Kích thước tham khảo. Có thể sản xuất theo thông số khách hàng yêu cầu*

**PROTECTION CURRENT TRANSFORMER (PCT) – ROUND TYPE/  
BIẾN DÒNG BẢO VỆ (PCT) – LOẠI TRÒN**

Photo/ Hình ảnh	Order code/ Mã đặt hàng	Ratio/ Tỉ số (A)	Class/ CCX	Burden/ Dung lượng (VA)	Dimension (mm)/ Kích thước			
					ID	OD	T	H
	PCT/100/510/5	100/5	5P10	5VA	25	115	80	130
	PCT/150/510/5	150/5	5P10	5VA	25	95	80	110
	PCT/200/510/5	200/5	5P10	5VA	30	95	70	110
	PCT/250/510/5	250/5	5P10	5VA	30	90	70	110
	PCT/300/510/5	300/5	5P10	5VA	30	90	60	110
	PCT/400/510/5	400/5	5P10	5VA	45	95	60	115
	PCT/500/510/5	500/5	5P10	5VA	55	100	60	115
	PCT/600/510/5	600/5	5P10	5VA	55	100	60	115
	PCT/100/510/10	100/5	5P10	10VA	25	120	110	135
	PCT/150/510/10	150/5	5P10	10VA	25	110	90	125
	PCT/200/510/10	200/5	5P10	10VA	30	110	70	125
	PCT/250/510/10	250/5	5P10	10VA	30	100	80	115
	PCT/300/510/10	300/5	5P10	10VA	30	100	70	115

Photo/ Hình ảnh	Order code/ Mã đặt hàng	Ratio/ Tỉ số (A)	Class/ CCX	Burden/ Dung lượng (VA)	Dimension (mm)/ Kích thước			
					ID	OD	T	H
	PCT/400/510/5	400/5	5P10	10VA	45	100	70	115
	PCT/500/510/5	500/5	5P10	10VA	55	105	70	120
	PCT/600/510/5	600/5	5P10	10VA	55	105	70	120
	PCT/150/510/10	150/5	5P10	15VA	25	120	110	135
	PCT/200/510/10	200/5	5P10	15VA	30	120	90	135
	PCT/250/510/10	250/5	5P10	15VA	30	110	90	125
	PCT/300/510/10	300/5	5P10	15VA	30	100	90	115
	PCT/400/510/15	400/5	5P10	15VA	45	105	80	120
	PCT/500/510/15	500/5	5P10	15VA	55	115	70	130
	PCT/600/510/15	600/5	5P10	15VA	55	110	70	125
	PCT/800/510/15	800/5	5P10	15VA	75	130	60	145
	PCT/1000/510/15	1000/5	5P10	15VA	75	130	60	145
	PCT/1200/510/15	1200/5	5P10	15VA	75	130	50	145
	PCT/1250/510/15	1250/5	5P10	15VA	75	130	50	145
	PCT/1600/510/15	1600/5	5P10	15VA	90	140	50	155
	PCT/2000/510/15	2000/5	5P10	15VA	130	185	40	200
	PCT/2500/510/15	2500/5	5P10	15VA	130	185	40	200
	PCT/3000/510/15	3000/5	5P10	15VA	130	185	40	200
	PCT/3200/510/15	3200/5	5P10	15VA	130	185	40	200
	PCT/4000/510/15	4000/5	5P10	15VA	160	215	40	230
PCT/5000/510/15	5000/5	5P10	15VA	160	215	40	230	
PCT/6000/510/15	6000/5	5P10	15VA	160	215	40	230	
PCT/6300/510/15	6300/5	5P10	15VA	160	215	40	230	

**PROTECTION CURRENT TRANSFORMER (PCT) – SQUARE TYPE/  
BIẾN DÒNG BẢO VỆ (PCT) – LOẠI VUÔNG**

Photo/ Hình ảnh	Order code/ Mã đặt hàng	Ratio/ Tỉ số (A)	Class/ CCX	Burden/ Dung lượng (VA)	Dimension (mm)/ Kích thước			
					ID	OD	T	H
	PCT/1600/510/15/S	1600/5	5P10	15VA	50 x 105	100 x 155	50	130
	PCT/2000/510/15/S	2000/5	5P10	15VA	50 x 105	100 x 155	50	130
	PCT/2500/510/15/S	2500/5	5P10	15VA	50 x 105	100 x 155	50	130
	PCT/3000/510/15/S	3000/5	5P10	15VA	70 x 140	110 x 180	40	140
	PCT/3200/510/15/S	3200/5	5P10	15VA	70 x 140	110 x 180	40	140
	PCT/4000/510/15/S	4000/5	5P10	15VA	100 x 170	160 x 220	40	180
	PCT/5000/510/15/S	5000/5	5P10	15VA	100 x 170	160 x 220	40	180
	PCT/6000/510/15/S	6000/5	5P10	15VA	100 x 170	160 x 220	40	180
	PCT/6300/510/15/S	6300/5	5P10	15VA	100 x 170	160 x 220	40	180

*\*Dimension for reference. Other technical specifications can be made on request/ Kích thước tham khảo. Có thể sản xuất theo thông số khách hàng yêu cầu*

**Drawing/ bản vẽ**

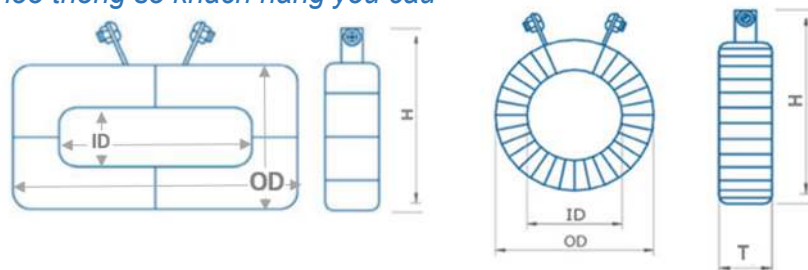

**MEASURING CURRENT TRANSFORMER (MCT) – ROUND TYPE/  
BIẾN DÒNG ĐO LƯỜNG (MCT) - LOẠI TRÒN**

Photo/ Hình ảnh	Order code/ Mã đặt hàng	Ratio/ Tỉ số (A)	Class/ Cấp chính xác	Burden/ Dung lượng (VA)	Dimension (mm)/ Kích thước			
					ID	OD	T	H
	MCT/1/5/50	50/5	1.0	5		80	55	120
	MCT/1/5/60	60/5	1.0	5		80	55	120
	MCT/1/5/75	75/5	1.0	5		80	55	120
	MCT/0.5/15/50	50/5	0.5	15		95	65	135
	MCT/0.5/15/60	60/5	0.5	15		95	65	135
	MCT/0.5/15/75	75/5	0.5	15		95	65	135
	MCT/0.5/15/100	100/5	0.5	15		95	65	135
	MCT/0.5/15/150	150/5	0.5	15		95	65	135
	MCT/3/5/50	50/5	3.0	5	20	100	80	140
	MCT/3/5/60	60/5	3.0	5	20	100	70	140
	MCT/3/5/75	75/5	3.0	5	20	100	70	140
	MCT/1/5/50(2T)	50/5 (2T)	1.0	5	25	100	60	140
	MCT/1/5/60(2T)	60/5 (2T)	1.0	5	25	100	60	140
	MCT/1/5/75(2T)	75/5 (2T)	1.0	5	25	100	60	140
	MCT/1/5/100	100/5	1.0	5	25	100	60	140
	MCT/1/5/150	150/5	1.0	5	25	100	60	140
	MCT/0.5/5/50(4T)	50/5 (4T)	0.5	5	35	100	60	140
	MCT/0.5/5/60(4T)	60/5 (4T)	0.5	5	35	100	60	140
	MCT/0.5/5/75(4T)	75/5 (4T)	0.5	5	35	100	55	140
	MCT/0.5/5/100(2T)	100/5 (2T)	0.5	5	60	115	45	155
	MCT/0.5/5/150(2T)	150/5 (2T)	0.5	5	60	115	40	155
	MCT/1/5/200	200/5	1.0	5	35	100	60	140
	MCT/1/5/250	250/5	1.0	5	35	100	60	140
	MCT/1/5/300	300/5	1.0	5	35	100	55	140
	MCT/1/5/400	400/5	1.0	5	60	115	45	155
	MCT/1/5/500	500/5	1.0	5	60	115	40	155
	MCT/1/5/600	600/5	1.0	5	60	115	40	155
	MCT/0.5/5/200	200/5	0.5	5	35	100	65	140
	MCT/0.5/5/250	250/5	0.5	5	35	100	65	140
	MCT/0.5/5/300	300/5	0.5	5	35	100	55	140
	MCT/0.5/5/400	400/5	0.5	5	60	115	50	155
	MCT/0.5/5/500	500/5	0.5	5	60	115	50	155
	MCT/0.5/5/600	600/5	0.5	5	60	115	50	155
	MCT/1/15/800	800/5	1.0	15	85	135	45	175
	MCT/1/15/1000	1000/5	1.0	15	85	135	45	175
	MCT/1/15/1200	1200/5	1.0	15	85	145	40	185
	MCT/1/15/1250	1250/5	1.0	15	85	145	40	185
	MCT/1/15/1600	1600/5	1.0	15	85	150	40	190
	MCT/1/15/2000	2000/5	1.0	15	125	195	40	235
	MCT/1/15/2500	2500/5	1.0	15	125	195	40	235
	MCT/1/15/3000	3000/5	1.0	15	125	200	40	240
	MCT/1/15/3200	3200/5	1.0	15	125	200	40	240
MCT/1/15/4000	4000/5	1.0	15	125	210	40	250	
MCT/1/15/5000	5000/5	1.0	15	160	235	40	275	
MCT/1/15/6000	6000/5	1.0	15	160	240	40	280	
MCT/1/15/6300	6300/5	1.0	15	160	240	40	280	

**MEASURING CURRENT TRANSFORMER (MCT) – ROUND TYPE/  
BIẾN DÒNG ĐO LƯỜNG (MCT) - LOẠI TRÒN**

Photo/ Hình ảnh	Order code/ Mã đặt hàng	Ratio/ Tỉ số (A)	Class/ Cấp chính xác	Burden/ Dung lượng (VA)	Dimension (mm)/ Kích thước			
					ID	OD	T	H
	MCT/0.5/15/800	800/5	0.5	15	85	135	50	175
	MCT/0.5/15/1000	1000/5	0.5	15	85	135	50	175
	MCT/0.5/15/1200	1200/5	0.5	15	85	145	50	185
	MCT/0.5/15/1250	1250/5	0.5	15	85	145	50	185
	MCT/0.5/15/1600	1600/5	0.5	15	85	150	45	195
	MCT/0.5/15/2000	2000/5	0.5	15	125	195	45	235
	MCT/0.5/15/2500	2500/5	0.5	15	125	195	45	235
	MCT/0.5/15/3000	3000/5	0.5	15	125	200	45	240
	MCT/0.5/15/3200	3200/5	0.5	15	125	200	45	240
	MCT/0.5/15/4000	4000/5	0.5	15	125	210	45	250
	MCT/0.5/15/5000	5000/5	0.5	15	160	235	45	275
	MCT/0.5/15/6000	6000/5	0.5	15	160	240	45	280
	MCT/0.5/15/6300	6300/5	0.5	15	160	240	45	280

**MEASURING CURRENT TRANSFORMER (MCT) – SQUARE TYPE/  
BIẾN DÒNG ĐO LƯỜNG (MCT) – LOẠI HÌNH CHỮ NHẬT**

Photo/ Hình ảnh	Order code/ Mã đặt hàng	Ratio/ Tỉ số (A)	Class/ Cấp chính xác	Burden/ Dung lượng (VA)	Dimension (mm)/ Kích thước			
					ID	OD	T	H
	MCT/1/15/800/S	800/5	1.0	15	50x85	110x145	45	170
	MCT/1/15/1000/S	1000/5	1.0	15	50x85	110x145	45	170
	MCT/1/15/1200/S	1200/5	1.0	15	50x85	110x145	40	170
	MCT/1/15/1250/S	1250/5	1.0	15	50x85	110x145	40	170
	MCT/1/15/1600/S	1600/5	1.0	15	50x85	110x145	40	170
	MCT/1/15/2000/S	2000/5	1.0	15	50x85	110x145	40	170
	MCT/1/15/2500/S	2500/5	1.0	15	80x120	140x180	40	205
	MCT/1/15/3000/S	3000/5	1.0	15	80x120	140x180	40	205
	MCT/1/15/3200/S	3200/5	1.0	15	80x120	140x180	40	205
	MCT/1/15/4000/S	4000/5	1.0	15	80x150	145x215	40	240
	MCT/1/15/5000/S	5000/5	1.0	15	80x150	150x220	40	265
	MCT/1/15/6000/S	6000/5	1.0	15	80x150	160x220	40	265
	MCT/1/15/6300/S	6300/5	1.0	15	80x150	160x220	40	265
	MCT/0.5/15/800/S	800/5	0.5	15	50x85	110x145	50	170
	MCT/0.5/15/1000/S	1000/5	0.5	15	50x85	110x145	50	170
	MCT/0.5/15/1200/S	1200/5	0.5	15	50x85	110x145	50	170
	MCT/0.5/15/1250/S	1250/5	0.5	15	50x85	110x145	50	170
	MCT/0.5/15/1600/S	1600/5	0.5	15	50x85	110x145	45	170
	MCT/0.5/15/2000/S	2000/5	0.5	15	50x85	110x145	45	170
	MCT/0.5/15/2500/S	2500/5	0.5	15	80x120	140x180	45	205
	MCT/0.5/15/3000/S	3000/5	0.5	15	80x120	140x180	45	205
	MCT/0.5/15/3200/S	3200/5	0.5	15	80x120	140x180	45	205
	MCT/0.5/15/4000/S	4000/5	0.5	15	80x150	145x215	45	240
	MCT/0.5/15/5000/S	5000/5	0.5	15	80x150	150x220	45	265
	MCT/0.5/15/6000/S	6000/5	0.5	15	80x150	160x220	45	265
	MCT/0.5/15/6300/S	6300/5	0.5	15	80x150	160x220	45	265

**PROTECTION CURRENT TRANSFORMER (PCT) – ROUND TYPE**  
**BIẾN DÒNG BẢO VỆ (PCT) – LOẠI TRÒN**

Photo/ Hình ảnh	Order code/ Mã đặt hàng	Ratio/ Tỉ số (A)	Class/ Cấp chính xác	Burden/ Dung lượng (VA)	Dimension (mm)/ Kích thước			
					ID	OD	T	H
	PCT/510/5/100	100/5	5P10	5	25	100	110	140
	PCT/510/5/150	150/5	5P10	5	25	100	90	140
	PCT/510/5/200	200/5	5P10	5	35	105	80	140
	PCT/510/5/250	250/5	5P10	5	35	105	75	145
	PCT/510/5/300	300/5	5P10	5	35	105	70	145
	PCT/510/5/400	400/5	5P10	5	42	115	75	155
	PCT/510/5/500	500/5	5P10	5	60	115	65	155
	PCT/510/5/600	600/5	5P10	5	60	115	60	155
	PCT/510/10/100	100/5	5P10	10	25	100	170	140
	PCT/510/10/150	150/5	5P10	10	25	100	115	140
	PCT/510/10/200	200/5	5P10	10	35	105	105	145
	PCT/510/10/250	250/5	5P10	10	35	105	100	145
	PCT/510/10/300	300/5	5P10	10	35	105	95	145
	PCT/510/10/400	400/5	5P10	10	42	115	80	155
	PCT/510/10/500	500/5	5P10	10	60	115	70	155
	PCT/510/10/600	600/5	5P10	10	60	115	70	155
	PCT/510/15/150	150/5	5P10	15	25	100	120	140
	PCT/510/15/200	200/5	5P10	15	35	105	110	145
	PCT/510/15/250	250/5	5P10	15	35	105	105	145
	PCT/510/15/300	300/5	5P10	15	35	105	100	145
	PCT/510/15/400	400/5	5P10	15	42	115	85	155
	PCT/510/15/500	500/5	5P10	15	60	115	75	155
	PCT/510/15/600	600/5	5P10	15	60	115	70	155
	PCT/510/20/150	150/5	5P10	20	25	100	200	140
	PCT/510/20/200	200/5	5P10	20	35	105	170	145
	PCT/510/20/250	250/5	5P10	20	35	105	155	145
	PCT/510/20/300	300/5	5P10	20	35	105	135	145
	PCT/510/20/400	400/5	5P10	20	42	115	130	155
	PCT/510/20/500	500/5	5P10	20	60	115	120	155
	PCT/510/20/600	600/5	5P10	20	60	115	105	155
	PCT/510/15/800	800/5	5P10	15	85	145	55	185
	PCT/510/15/1000	1000/5	5P10	15	85	145	55	185
	PCT/510/15/1200	1200/5	5P10	15	85	145	55	185
	PCT/510/15/1250	1250/5	5P10	15	85	145	55	185
	PCT/510/15/1600	1600/5	5P10	15	90	145	55	185
	PCT/510/15/2000	2000/5	5P10	15	125	195	50	235
	PCT/510/15/2500	2500/5	5P10	15	125	200	50	240
	PCT/510/15/3000	3000/5	5P10	15	125	205	50	245
	PCT/510/15/3200	3200/5	5P10	15	125	205	50	245
	PCT/510/15/4000	4000/5	5P10	15	125	210	50	250
PCT/510/15/5000	5000/5	5P10	15	160	230	50	270	
PCT/510/15/6000	6000/5	5P10	15	160	240	50	280	
PCT/510/15/6300	6300/5	5P10	15	160	240	50	280	
PCT/510/20/800	800/5	5P10	20	85	145	60	185	
PCT/510/20/1000	1000/5	5P10	20	85	145	60	185	
PCT/510/20/1200	1200/5	5P10	20	85	145	60	185	
PCT/510/20/1250	1250/5	5P10	20	85	145	60	185	
PCT/510/20/1600	1600/5	5P10	20	90	145	60	185	

	PCT/510/20/2000	2000/5	5P10	20	125	195	55	245
	PCT/510/20/2500	2500/5	5P10	20	125	200	55	240
	PCT/510/20/3000	3000/5	5P10	20	125	205	55	245
	PCT/510/20/3200	3200/5	5P10	20	125	205	55	245
	PCT/510/20/4000	4000/5	5P10	20	125	210	55	250
	PCT/510/20/5000	5000/5	5P10	20	160	230	55	270
	PCT/510/20/6000	6000/5	5P10	20	160	240	55	280
	PCT/510/20/6300	6300/5	5P10	20	160	240	55	280

**PROTECTION CURRENT TRANSFORMER (PCT) – SQUARE TYPE**  
**BIẾN DÒNG BẢO VỆ (PCT) – LOẠI HÌNH CHỮ NHẬT**

Photo/ Hình ảnh	Order code/ Mã đặt hàng	Ratio/ Tỉ số (A)	Class/ Cấp chính xác	Burden (VA)/ Dung lượng	Dimension (mm)/ Kích thước			
					ID	OD	T	H
	PCT/510/15/800/S	800/5	5P10	15	50x85	110x145	100	170
	PCT/510/15/1000/S	1000/5	5P10	15	50x85	110x145	85	170
	PCT/510/15/1200/S	1200/5	5P10	15	50x85	110x145	85	170
	PCT/510/15/1250/S	1250/5	5P10	15	50x85	110x145	85	170
	PCT/510/15/1600/S	1600/5	5P10	15	50x85	110x145	70	170
	PCT/510/15/2000/S	2000/5	5P10	15	50x85	110x145	70	170
	PCT/510/15/2500/S	2500/5	5P10	15	80x120	140x180	70	205
	PCT/510/15/3000/S	3000/5	5P10	15	80x120	140x180	70	205
	PCT/510/15/3200/S	3200/5	5P10	15	80x120	140x180	70	205
	PCT/510/15/4000/S	4000/5	5P10	15	80x150	145x215	70	240
	PCT/510/15/5000/S	5000/5	5P10	15	80x150	150x220	70	245
	PCT/510/15/6000/S	6000/5	5P10	15	80x150	160x220	70	245
	PCT/510/15/6300/S	6300/5	5P10	15	80x150	160x220	70	245
	PCT/510/20/800/S	800/5	5P10	20	50x85	110x145	120	170
	PCT/510/20/1000/S	1000/5	5P10	20	50x85	110x145	105	170
	PCT/510/20/1200/S	1200/5	5P10	20	50x85	110x145	105	170
	PCT/510/20/1250/S	1250/5	5P10	20	50x85	110x145	105	170
	PCT/510/20/1600/S	1600/5	5P10	20	50x85	110x145	90	170
	PCT/510/20/2000/S	2000/5	5P10	20	50x85	110x145	90	170
	PCT/510/20/2500/S	2500/5	5P10	20	80x120	140x180	90	205
	PCT/510/20/3000/S	3000/5	5P10	20	80x120	140x180	90	205
	PCT/510/20/3200/S	3200/5	5P10	20	80x120	140x180	90	205
	PCT/510/20/4000/S	4000/5	5P10	20	80x150	145x215	90	240
	PCT/510/20/5000/S	5000/5	5P10	20	80x150	150x220	90	245
	PCT/510/20/6000/S	6000/5	5P10	20	80x150	160x220	90	245
	PCT/510/20/6300/S	6300/5	5P10	20	80x150	160x220	90	245

*\*Dimension for reference. Other technical specifications can be made on request/ Kích thước tham khảo. Có thể sản xuất theo thông số khách hàng yêu cầu*

**Drawing/ bản vẽ**

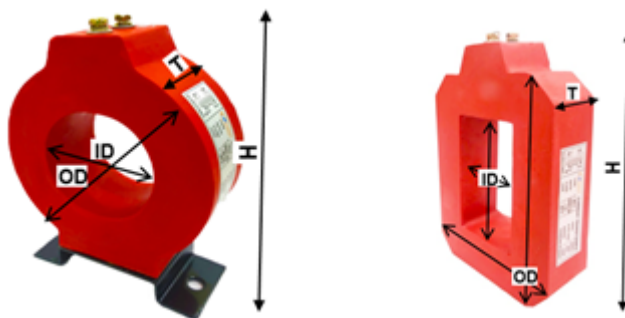

## ❖ MSP series/ Biến dòng dạng hồ

Photo/ Hình ảnh	Model/ Mã	Ratio/ Tỷ số (A)	Class/ Cấp chính xác	Burden (VA)/ Dung lượng	Dimension (mm)/ Kích thước				
					A	B	C	D	H
	MSP-23	100/5	1.0	2.5	21	31	89	111	40
		150/5	1.0	2.5	21	31	89	111	40
		200/5	1.0	5	21	31	89	111	40
		250/5	1.0	5	21	31	89	111	40
		300/5	1.0	5	21	31	89	111	40
		400/5	1.0	5	21	31	89	111	40
		500/5	1.0	5	21	31	89	111	40
	MSP-46	400/5	1.0	5	40	60	105	125	32
		500/5	1.0	5	40	60	105	125	32
		600/5	1.0	5	40	60	105	125	32
	MSP-58	800/5	1.0	10	51	81	114	145	32
		1000/5	1.0	15	51	81	114	145	32
		1200/5	1.0	15	51	81	114	145	32
		1600/5	1.0	15	51	81	114	145	32
		2000/5	1.0	15	51	81	114	145	32
	MSP-510	2000/5	1.0	15	52	102	115	180	32
	MSP-612	1000/5	1.0	15	62	125	125	192	32
		1200/5	1.0	15	62	125	125	192	32
		1600/5	1.0	15	62	125	125	192	32
		2000/5	1.0	15	62	125	125	192	32
		2500/5	1.0	15	62	125	125	192	32
	MSP-614	2000/5	1.0	25	62	142	125	210	32
		2500/5	1.0	25	62	142	125	210	32
		3000/5	1.0	25	62	142	125	210	32
		3200/5	1.0	25	62	142	125	210	32
	MSP-816	4000/5	1.0	25	82	162	184	245	52
	MSP-820	4000/5	1.0	25	82	202	184	285	52
		5000/5	1.0	25	82	202	184	285	52
		6000/5	1.0	25	82	202	184	285	52
		6300/5	1.0	25	82	202	184	285	52

Drawing/ bản vẽ

